



Pendant Speaker

Model: 700286198 / 700286206
(Black) (White)

Installation and Use Manual

Issue 1, August 2003

© 2003 Bogen Communications, Inc.
All rights reserved.
Specifications subject to change without notice.
54-2101-01A 0308 Printed in Taiwan.

Product Description

You have purchased one of the finest pendant loudspeakers available today. Please familiarize yourself with this product by reading and reviewing the following descriptions and diagrams.

These loudspeakers include a "spiderless" woofer that utilizes a high-gauss ferrofluid to guide the voice coil through the magnetic field. The benefits over conventional woofers with cloth spiders are several, including the ability to constantly adjust voice coil alignment, extend linear excursion, and the most efficient path for cooling the voice coil.

In addition, the use of metal-alloy cone structures provides several benefits over the usual paper or plastic cone, such as elimination of cone flex or "break-up" in the operating ranges, additional thermal path for the voice coil to stay cool, and an extremely stable cone structure unaffected by the environment.

The pendant loudspeaker is a full-range, wide dispersion system providing overhead sound coverage where ceiling structures are high but the sound needs to be closer to the audience/listener. Cable kits are provided for use as safety and main drop cables.

Settings for 70V and 100V high-impedance systems, as well as a low-impedance (16-ohm) position, are provided.

All models feature a removable snap-lock input connector, providing easy wire connection for input as well as loop-through to the next speaker.

Product Diagrams

Front Drawing

1. Tap Selection Switch
2. Coaxial Driver Assembly
3. Grille Retention Slot
4. Bass Tuning Vent (x2)
5. Perforated Steel Grille

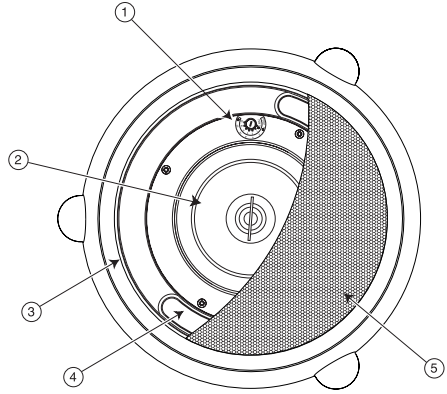

Front Drawing
(grille partially shown)

Rear Drawing

1. Snap-Lock Input Connector
2. Suspension Points (x3)
3. Safety Cable Suspension Point

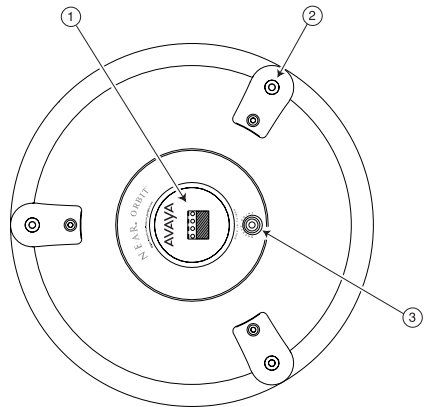

Rear Drawing

Package Contents

- (1) Pendant Speaker
- (1) Installation and Use Manual
- (1) Snap-Lock Input Connector
- (1) Quick-Snap Clip
- (2) Cable Kits
- (3) Suspension Cables with Forged Eye Bolts
- (3) Nuts (may be installed onto eyebolts)

Speaker Installation

If the power level is known, then select it using the front-mounted selector switch prior to installing the speaker. See section *Selecting Power Levels*.

Speaker Grille Removal

Insert a pocket knife blade between the grille and the bezel about a $\frac{1}{4}$ " deep and then gently pry the grille upwards. Do this in multiple places around the circumference of the grille to free the grille.

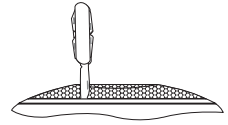

Speaker Grille Installation

The speaker grilles fit tightly! Make sure the tap settings are correct prior to installing grille. Push the speaker grille in until it can go no further. Then, slap around the edge of the grille to seat the grille. The grille is properly seated when it is flush with the edge of the bezel.

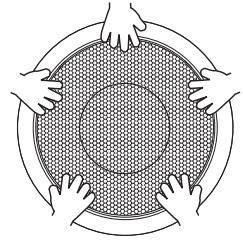

Suspension Cable Assembly

1. Screw nuts onto the eye bolts all the way to the flange.
2. Screw in eye bolts with captured cable sections in to the three suspension points. Do not overtighten.
3. Snap loops of free end of cable sections into quick-snap clip.
4. Connect quick-snap clip to drop cable. The supplied cable kit is suitable for use as the drop cable.

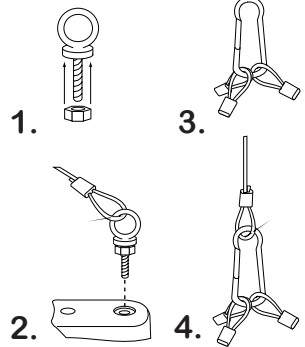

Safety Cable

The speaker includes a safety cable suspension point for extra protection. The included cable kit must be used as a safety cable. Refer to instructions with cable kits for proper use.

IMPORTANT

The anchor point and any hardware used to anchor the speaker must be able to support the speaker's weight under all conditions. IF YOU ARE NOT SURE OF THE PROPER CAPACITY OF THESE ITEMS TO USE, CONSULT A STRUCTURAL ENGINEER. Mount only one speaker per supplied quick-snap clip.

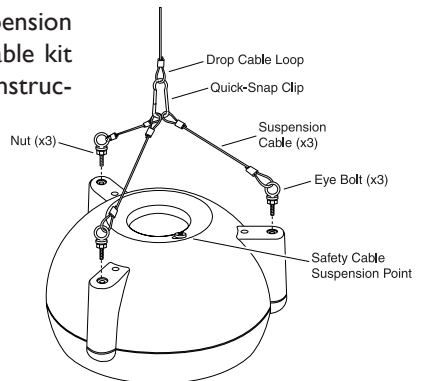

Speaker Wiring

Wiring is terminated at a snap-lock input connector. There are two positive and two negative terminals to accommodate daisy chaining of speakers in a system. All wiring should be done prior to installation and then plugged into the rear of the speaker.

Daisy Chaining

The speaker's snap-lock input connector allows for easy daisy chaining of speakers by providing a second terminal of each polarity. Refer to the figures for proper wiring for daisy chaining of terminals.

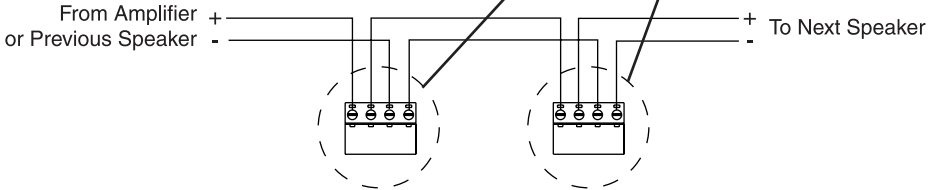

Speaker Phasing

Keep the same polarity terminals wired together to ensure correct phasing. In order to provide the best possible sound, all of the speakers in a system need to be pushing out and pulling in at the same time.

If the connections to one speaker in a system are reversed from the others, that speaker's movement will be out of sync with the other speakers. This will result in a loss of low frequency response and will effect the overall performance of the system.

Selecting Power Levels

The front-mounted selector switch is used to set the appropriate power level or impedance for your system. Using a small flat-blade screwdriver, turn the knob until the slot points to the power level you require.

70V/100V Systems

Both power setting scales for 70V and 100V systems are labeled on the speakers. On the 100V scale, the last position clockwise is marked with a Ⓢ (not available) symbol. Do not use this position in 100V systems.

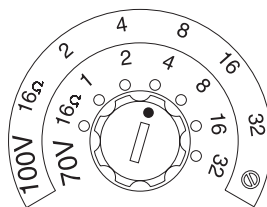

16Ω Systems

The fully counterclockwise position of the setting switch is the 16-ohm position. This setting is suitable for use with low-impedance amplifiers that typically support 4- or 8-ohm speakers. The speaker's higher, 16-ohm impedance makes it easier to combine multiple speakers into series - parallel networks while keeping the total system impedance at a level suitable for low-impedance amplifiers.

Specifications

SPECIFICATIONS	700286198 & 700286206
Frequency Response (-10 dB)*	60 Hz to 19 kHz
LF Driver	6-1/2" MDT Metal-Alloy Cone
HF Driver	20 mm (3/4") Polycarbonate Dome
Sensitivity (1W/1M)	89.5 dBspl (Average 100 Hz - 10 kHz)
Impedance Ratings	Low (16 ohms) / High (70V/100V)
Power Input (Max.)	100W @ 16 ohms; 32W @ 70V/100V
Power Settings (in watts)†	70V: 32, 16, 8, 4, 2, 1 100V: 32, 16, 8, 4, 2
Enclosure Material	ABS
Grille Material	Powder-Coated Perforated Metal
Terminations	4 Terminal Snap-Lock Input Connector
Product Weight	10 lb.
Speaker Dimensions	15" dia. x 9-1/4" D
Included Accessories	(1) Snap-Lock Input Connector; (1) Quick-Snap Clip (2) Cable Kits; (3) Nuts; and (3) Suspension Cables with Forged Eye Bolts
Enclosure Finish & Color	Textured White or Black

* Free Space Response, 16-ohm input.

† Front panel, switch-selected.

AVAYA

©2003 Bogen Communications, Inc.
Specifications are subject to change without notice.
www.paging-solutions.com
1-877-852-PAGE