

PEC Code: 5331-200 COM Code: 408184117 Model: LU15W70VH	15 WATT HORN
PEC Code: 5331-205 COM Code: 408184133 Model: LU30W70VH	30 WATT HORN



Horn Loudspeaker

Speaker Installation

STEP 1 - For easier installation, remove the flange (base) from the speaker by unscrewing the wing nut while at the same time pressing inwardly on the wing nut. Place the flange flush with the mounting surface and mark the location of the three holes with either a marker or chisel. It is important that the three holes be exactly aligned with the flange, otherwise you might stress the base or make the connection unsteady. Insert 3 wall anchors - see diagrams on back for drilling instructions and use of anchors. (Use appropriate hardware for your specific mounting surface.)

NOTE: Speaker may also be strap-mounted through the slot in flange (base) using standard 1/2-inch industrial strapping (not included).

STEP 2 - After mounting the flange, reattach the speaker to the flange and aim the speaker for the desired coverage. A 45° downward angle is recommended, but this may vary depending upon speaker layout. Unless otherwise indicated, do not aim speakers directly at each other or poor paging intelligibility may occur.

STEP 3 - Remove the plastic cover to make the electrical connection and set the tap set control (see Figure 2). **Note:** Use 22 AWG shielded, twisted pair on all wire runs. Connect speaker wire shield to the ground (GND) terminal of the amplifier's output. Carry the ground through all speaker cables by tying the shields of the speaker cables together in a "daisy chain" fashion. **Do not connect the shield to the speaker itself.** The shield is only connected at the amplifier end and simply floats.

Connect wires as listed below:

Amplifier Outputs	Speaker Connections
70V	Terminal 1
COM	Terminal 2

NOTE: The speaker will also work perfectly well with these connections reversed. However, reduced low frequency response may result.

STEP 4 - Adjust the tap set control to the desired setting. See table at right for tap settings and sound pressure levels for the different horn loudspeakers. Replace the plastic protective cover back over the exposed area.

NOTE: The two furthestmost clockwise settings on the volume control will produce the same volume.

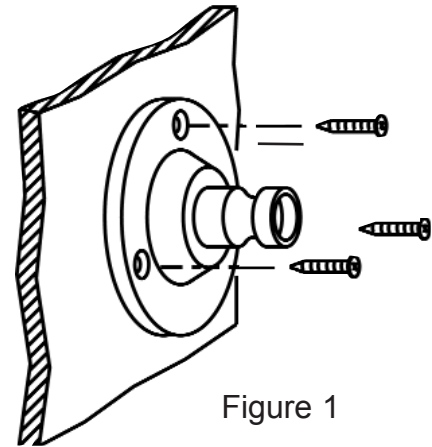

Figure 1

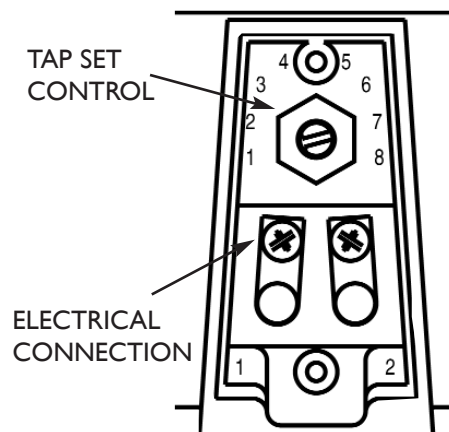

Figure 2

TAP SET	30 WATT HORN		15 WATT HORN	
	WATTS	dBspl* @ 70V	WATTS	dBspl* @ 70V
1	0.9	110	0.5	106
2	1.9	113	0.9	109
3	3.8	116	1.9	112
4	7.5	119	3.8	115
5	15	122	7.5	118
6	30	125	15	121
7+	30	125	15	121
8	not used		--	--

* at four feet

+ 7 is the furthest position control switch will turn

Using Anchors with Hollow Walls

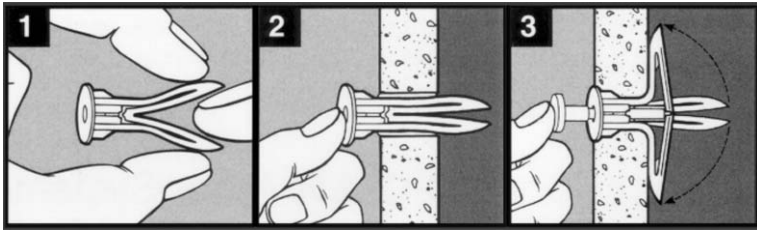

Drill 5/16" diameter hole for each anchor and screw.

Fold and insert anchor in hole (see Figure 1).

Tap anchor until it is flush with the wall (see Figure 2).

Insert red key to pop anchor open behind wall (see Figure 3). **DO NOT HAMMER KEY.**

Remove key.

Place speaker flange (base) over anchors.

Insert screws and tighten until flush with the mounting surface. Do not over tighten.

Using Anchors with Solid Walls

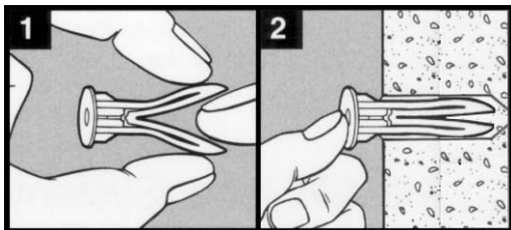

Drill 5/16" diameter hole (minimum hole depth for solid walls is 1 1/2") for each anchor and screw.

Fold and insert anchor in hole (see Figure 1).

Tap anchor until it is flush with the wall (see Figure 2).

Place speaker flange (base) over anchors.

Insert screws and tighten until flush with the mounting surface. Do not over tighten.